

# GENERAL CONSTRUCTION

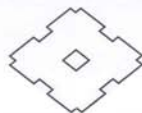

Fig. B-1 Single Reduction (Horizontal Foot Mount)

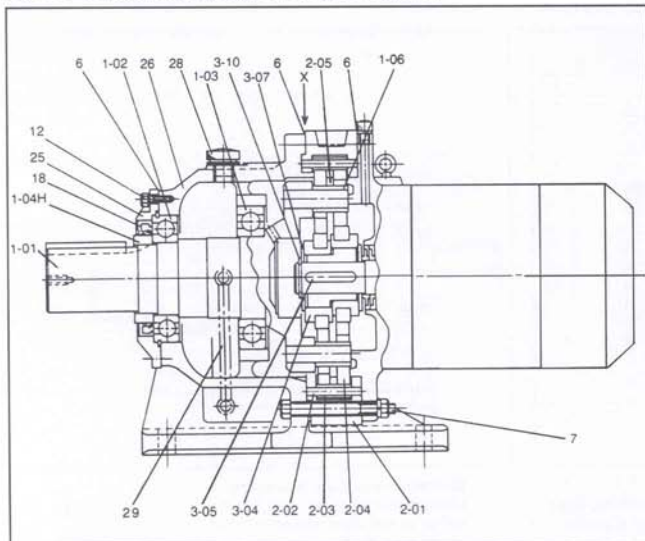
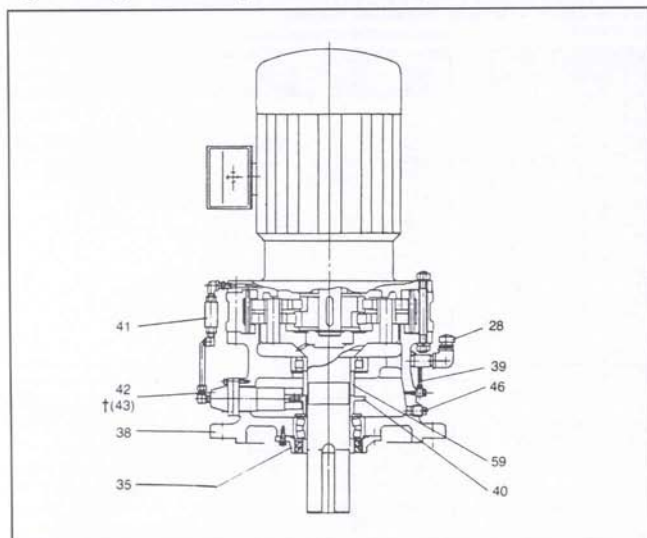

Fig. B-2 Single Reduction (Vertical Base Mount)



Note: For details of oil seals, bearings or gaskets, refer to pages B-10 and B-11.

†Refer to Table B-13 on Pg. B-9 for units that require a positive displacement pump.

Table B-1 Main Parts

Part No.	Part Name
1-01	Slow Speed Shaft w/pins
1-02	Bearing A
1-03	Bearing B
1-04H	Oil Seal Collar—Horizontal
1-06	Slow Speed Shaft Rollers
2-01	Ring Gear Housing
2-02	Ring Gear Pins
2-03	Ring Gear Rollers
2-04	Cyclo Disc
2-05	Spacer Ring
3-04	Eccentric Bearing Assembly
3-05	Eccentric Key
**3-06	Balance Weight
3-07	Spacer
3-10	Retaining Ring
‡5-01	Intermediate Shaft w/Pins
‡5-02	Bearing F
‡5-03	Bearing G
‡5-04	Eccentric Bearing Assembly
6	Gasket Set
7	Casing Nuts & Bolts
12	Bolts For SS Oil Seal Housing
‡15	Grease Nipple
18	Slow Speed Output Oil Seal
25	Horizontal Oil Seal Housing
26	Horizontal Case
28	Oil Fill Plug
29	Oil Gauge—Horizontal Unit
35	Vertical Oil Seal Housing
38	Vertical Case (Integral V Type)
39	Oil Gauge—Vertical Unit
40	Cam
41	Piping Set & Oil Signal
42	Plunger Pump
†43	Positive Displacement Pump
46	Drain Plug
‡55	Intermediate Cover
‡57	Eye Bolt
*59	Spacer

\* Pt. No. 59 — frame sizes 6205-6275 only.

\*\* See Fig. B-3, Page B-4.

‡ See Fig. B-4, Page B-4.

# GENERAL CONSTRUCTION

Fig. B-3 Gearmotor/Single Disc Type (Frame Size 6060-6095)

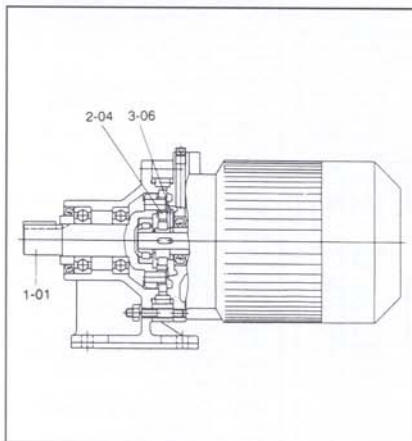

**Speed Reducer — Single Disc**  
SM-CYCLO single reduction, Models No. 6060-6095 employ the use of a single planetary gear (Cycloid Disc) and a balance weight.

Fig. B-4 Gearmotor/Double Reduction

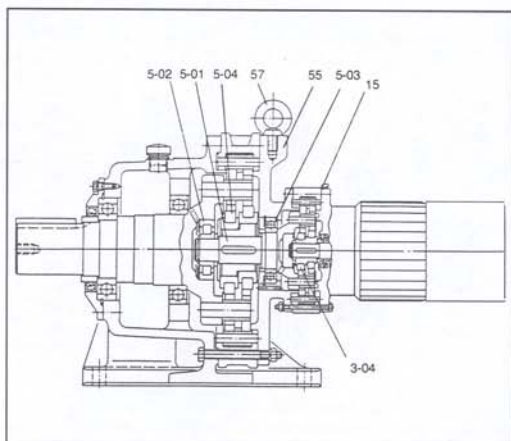

**Multiple Reduction Reducers**  
Multiple reduction SM-CYCLO Reducers are a combination of standard reduction mechanism assemblies connected using an intermediate shaft (Part No. 5-01) and intermediate cover (Part No. 55) between them.

Table B-2. Frame Sizes and Ratio Combination of Double Reduction Models

Frame Size Combination

Frame Size	Second Stage	First Stage
6060DA	6060	6060
6065DA	6065	6065
6070DA	6070	6065
6075DA	6075	6065
6090DA	6090	6075
6095DA	6095	6075
6100DA	6100	6075
6105DA	6105	6075
6120DA	6120	6075
6120DB	6120	6095
6125DA	6125	6075
6125DB	6125	6095
6130DA	6130	6075
6130DB	6130	6095
6130DC	6130	6105
6135DA	6135	6075
6135DB	6135	6095
6135DC	6135	6105
6140DA	6140	6075
6140DB	6140	6095
6140DC	6140	6105
6145DA	6145	6075
6145DB	6145	6095
6145DC	6145	6105
6160DA	6160	6095
6160DB	6160	6105
6160DC	6160	6125
6165DA	6165	6095
6165DB	6165	6105

Frame Size	Second Stage	First Stage
6165DC	6165	6125
6170DA	6170	6095
6170DB	6170	6105
6170DC	6170	6125
6175DA	6175	6095
6175DB	6175	6105
6175DC	6175	6125
6180DA	6180	6105
6180DB	6180	6135
6185DA	6185	6105
6185DB	6185	6135
6190DA	6190	6125
6190DB	6190	6135
6195DA	6195	6125
6195DB	6195	6135
6205DA	6205	6125
6205DB	6205	6135
6215DA	6215	6135
6215DB	6215	6165
6225DA	6225	6135
6225DB	6225	6175
6235DA	6235	6165
6235DB	6235	6185
6245DA	6245	6165
6245DB	6245	6185
6255DA	6255	6175
6255DB	6255	6195
6265DA	6265	6195
6275DA	6275	6195

Reduction Ratio Combination

Total Ratio	Second Stage Ratio	First Stage Ratio
104	13	8
121	11	11
143	13	11
165	15	11
195	15	13
231	21	11
273	21	13
319	29	11
377	29	13
473	43	11
559	43	13
649	59	11
731	43	17
841	29	29
1003	59	17
1247	43	29
1479	87	17
1849	43	43
2065	59	35
2537	59	43
3045	87	35
3481	59	59
4437	87	51
5133 <sup>[1]</sup>	87	59
6177	87	71
7569	87	87

Note: [1] For frame sizes 6205DA, DB or DC - 6265DA, DB or DC, second stage ratio is 59 and first stage ratio is 87.